

MG3-8U-X

使用说明书

USER MANUAL

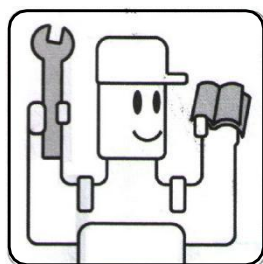

- 安装前，请仔细阅读安装说明书。
- PLEASE READ INSTRUCTIONS & ASSOCIATED DRAWINGS BEFORE INSTALLATION.

目录	INDEX
安装说明	INSTALLATION GUIDE
接线图	WIRING DIAGRAM
语言设置	LANGUAGE SETTING
归零校正	0KG CALIBRATION
调整	ADJUSTMENT
控制面板说明	CONTROL PANEL GUIDE
操控说明	OPERATION GUIDE
故障排除	TROUBLESHOOTING

组件名称
ACCESSORIES LIST

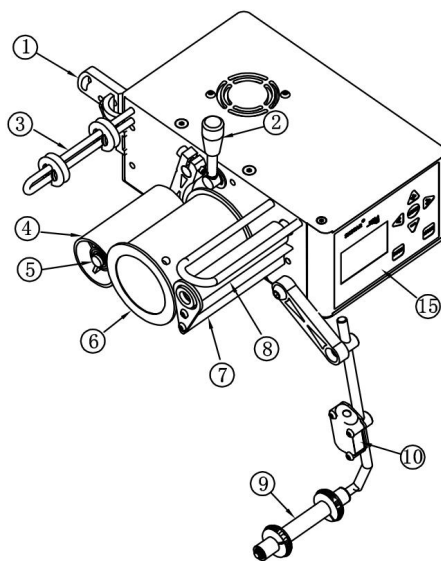

- | | |
|----------|--------------------------|
| 1.驱动组连结架 | 1.Joint |
| 2.把手 | 2.Handle Bar |
| 3.导带杆 | 3.Holder |
| 4.副轮 | 4.Auxiliary Roller |
| 5.副轮偏心轴 | 5.Auxiliary Roller Shaft |
| 6.驱动轮 | 6.Driven Roller |
| 7.保护架 | 7.Secure Holder |
| 8.感应轮 | 8.Secure Roller |

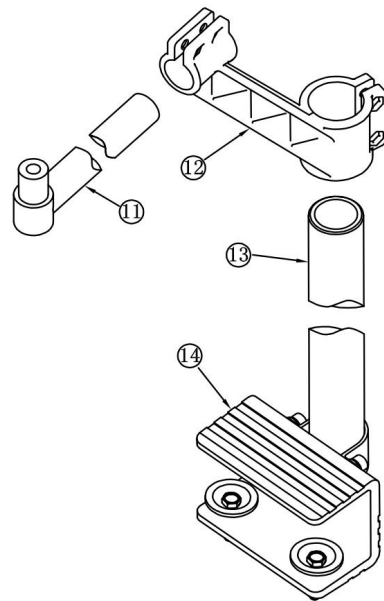

- | | |
|---------|----------------------|
| 9.辅助轮 | 9.Auxiliary Roller |
| 10.换段开关 | 10.Section Switching |
| 11.横杆 | 11.Arm |
| 12.连结架 | 12.Joint Stand |
| 13.支柱 | 13.Holder |
| 14.夹座 | 14.Clamping Base |
| 15.控制面板 | 15.Control Panel |

组合图

THE ASSEMBLE DIAGRAM

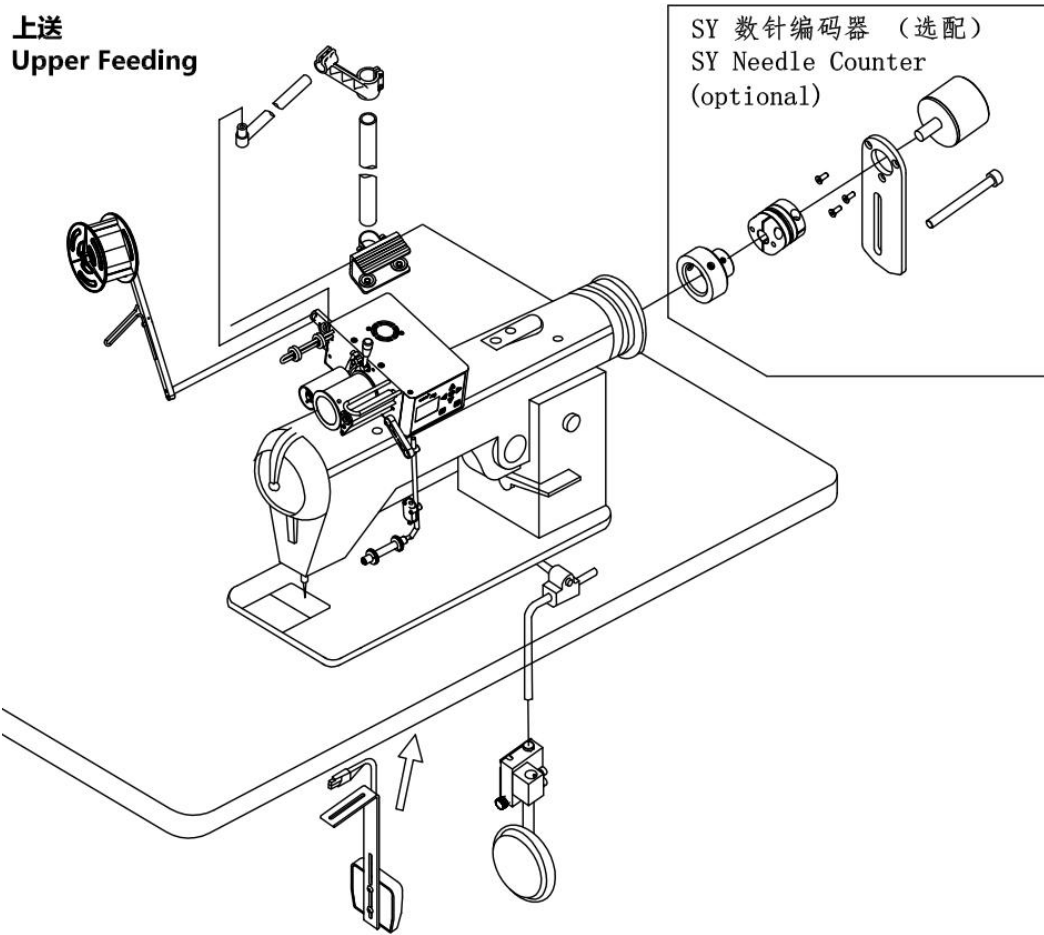

高度调整 HEIGHT

须预留车头旋转空间, 但不宜过高
Please keep some space for machine maintenance

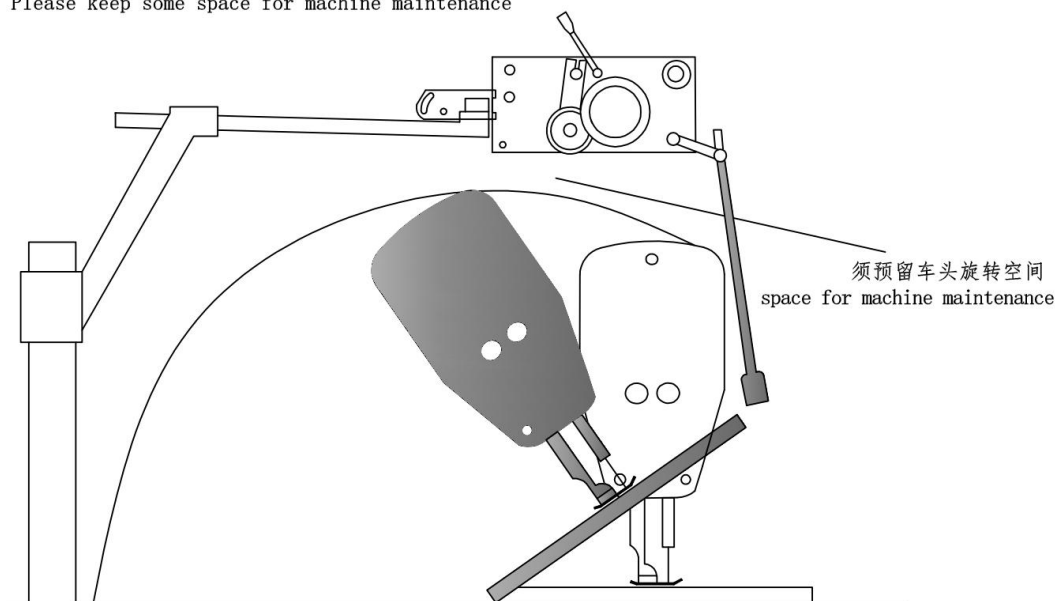

辅助杆调整 Auxiliary Guide

松紧带接触到车头, 将会影响到车缝尺寸, 可用辅助杆移开。
Please use the Auxiliary Guide to avoid the taps to contact the machine

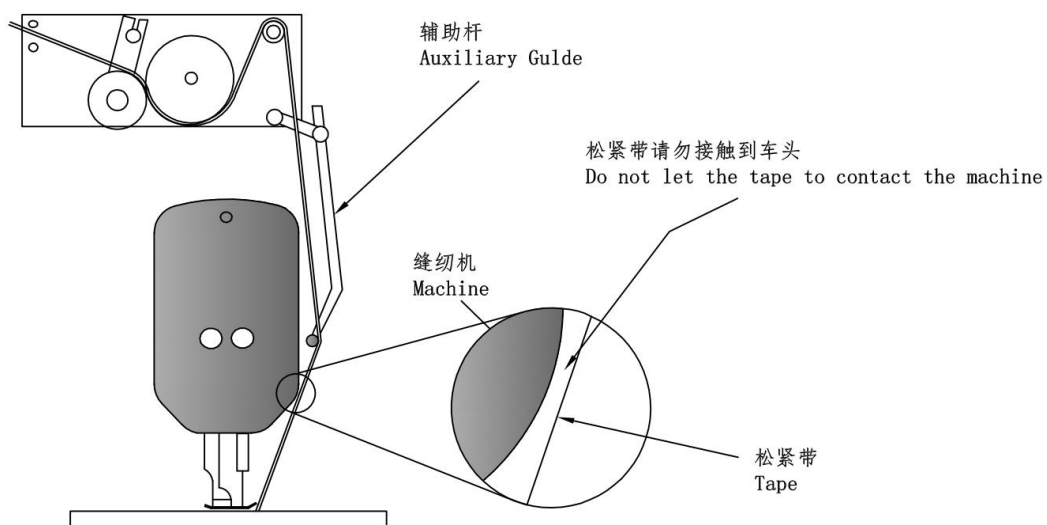

组合图

THE ASSEMBLE DIAGRAM

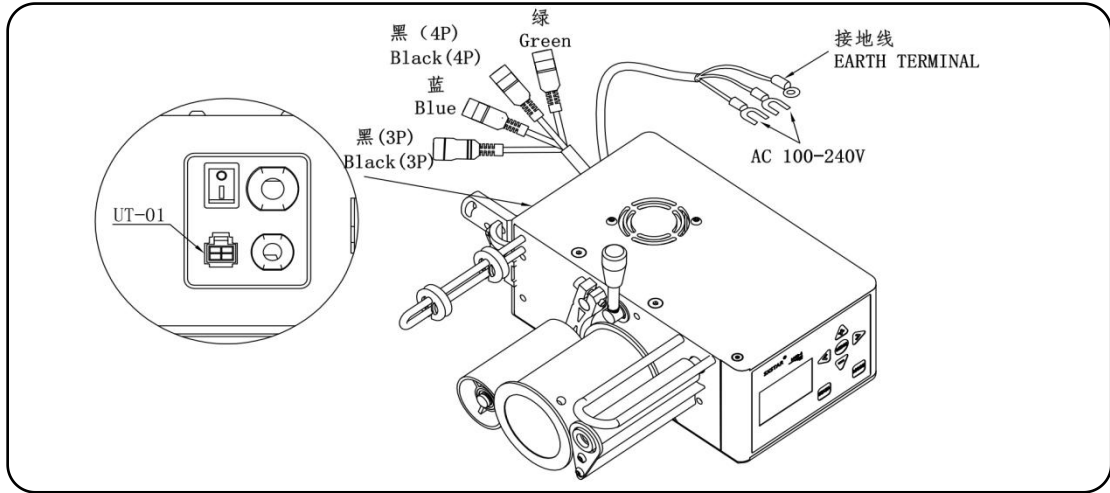

E9 无张力开关 (选配)
Zero-tension switch (Option)

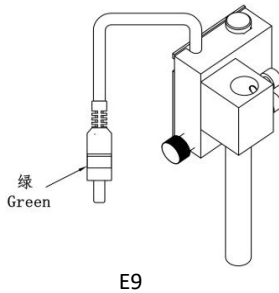

E6-1 悬吊无张力开关 (选配)
Suspensory zero-tension switch(option)

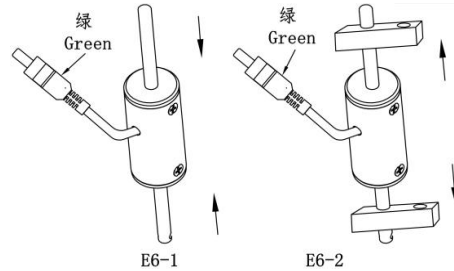

UT 电动防打结装置
UT Electric Anti-knotting device

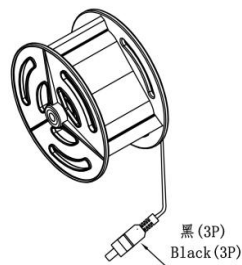

电源线
Power line

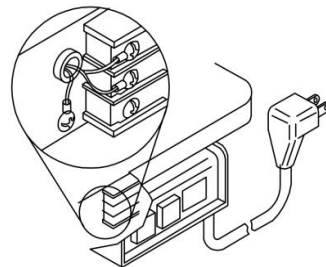

E8 膝部换段开关
Knee switch

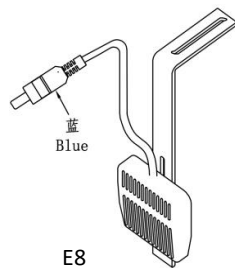

SY 数针编码器
SY Needle Counter

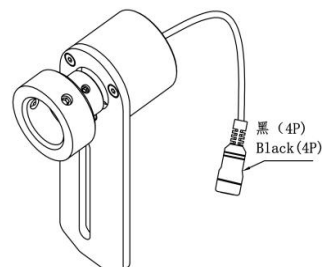

语言设置 LANGUAGE SETTING

语言设置说明

LANGUAGE SETTING GUIDE

面板语言设置：面板有中文和英文两种语言供用户选择

Panel language setting: provide Chinese and English for select

注意：功能设置选项中→符号指示所选内容，通过单击菜单键可以进入相应设置页面

Noted: the → symbol indicated that which option is selected, user can enter the corresponding settings mode by pressing the menu key

操作指引：

Operation guide:

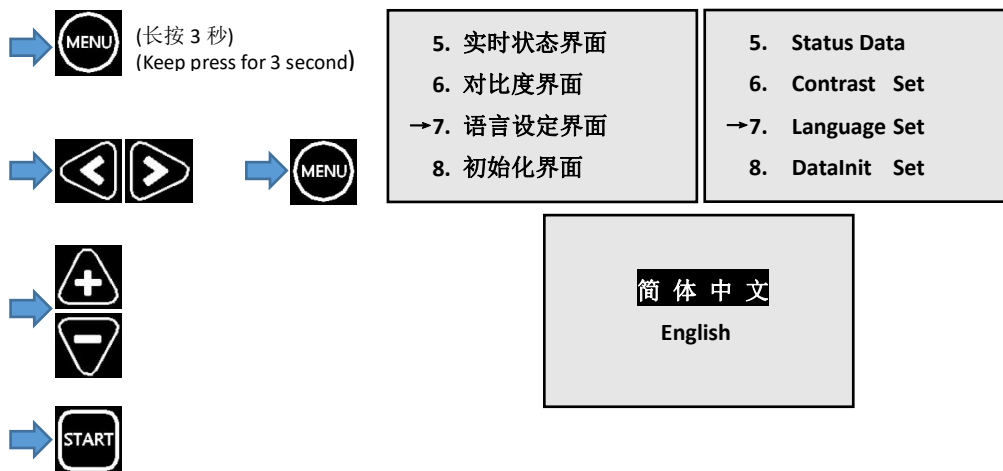

归零校正 OKG CALIBRATION

以下情况需要做归零校正:

Always correct the calibration after the following instances:

1. 本装置安装完成后
After installation.

尺寸出现异常不定时
If the device is feeding irregularly.

感应轮在无负载的状态（移开感应轮上的松紧带），在任何一段工程中，送料值在 980~990 之间，（灵敏度必须设定在 99），而驱动轮未停止转动时
If the driven roller can not stop. In any section. The driven roller must stop when the tension value to be adjusted between 980-990 and the sensitivity is set at 99 after remove the elastic tape from the sensor bar (Make sure nothing Contact with Sensor Bar).

操作指引:

Operation guide:



(长按 3 秒)
(Keep press for 3 second)



→1. 报警设定界面
2. 归零设定界面
3. 电流设定界面
4. 带料设定界面

→1. Beep Set
2. Zero Set
3. Current Set
4. Selector Set



压力系数 050
Pressure
OKG SET → 054
1KG SET 600

压力系数 050
Pressure
OKG SET → 050
1KG SET 600

注意: 如果归零后, 其数值不介于 10~90 之间, 则表示装置有问题, 需要检修

Notice: if the value is not between 10 ~ 90 after regular calibration, the device need to be repaired.

归零校正时应移开感应轮之松紧带 (如下图)

Please remove the elastic tape before calibration (Refer to the following figure).

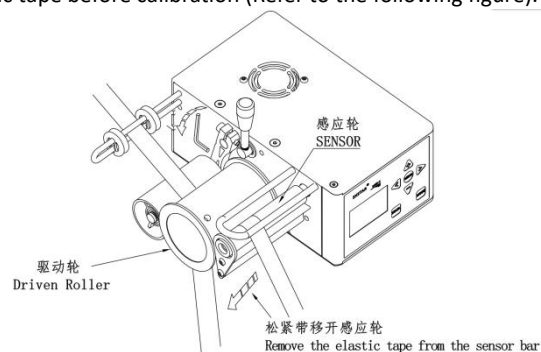

调整 ADJUSTMENTS

松紧带左右偏差调整

Adjustment for tape sliding over the roller

副轮偏心轴可调整松紧带左右的偏差

Adjust Eccentric Shaft of the Auxiliary Roller can let the tape to go the Right or Left side.

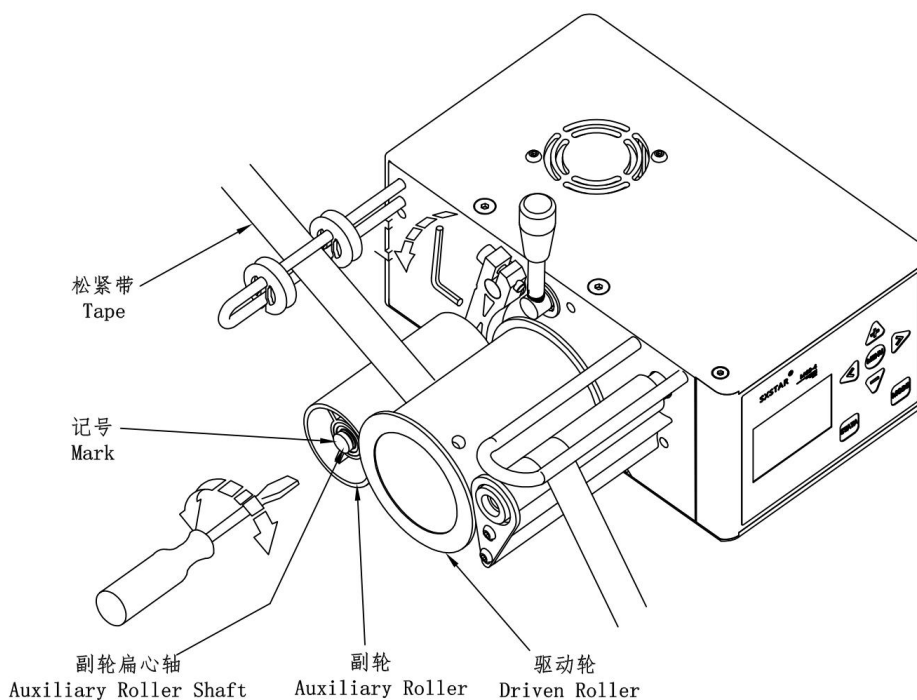

调整松紧带往左边
Adjust to the Left side

调整松紧带往右边
Adjust to the Right side

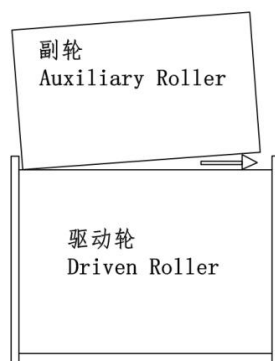
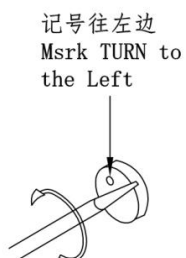
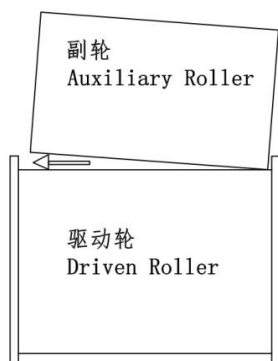

调整 ADJUSTMENTS

灵敏度调整说明：车缝时驱动轮及松紧带发生前后颤动不停时（如图 2），需适当调整灵敏度值，每段工程均可调整，

边调灵敏度、边用手拉松紧带，直到无震荡为止（如图 3）（灵敏度值从 00-99，出厂设定值为 ↓ 90）

Sensitivity adjustment: If the driven roller and elastic occur lasting vibration forward and backward while sewing. (Adjustable from 0-99. The default setting is 90) the tape must be pulled manually while the value is being adjusted. This allows you to feel if there is any vibration occurring (please refer to Figure 2 & Figure 3).

注意：如果灵敏度值调得过小，虽不会有震荡现象，但会影响尺寸的准确度。因此在不震荡的情况下值越大越好

Notice: If the value is too less. It will effect the accuracy. Therefore, the value is better with larger without vibration

图 2 调整前
Figure 2 Before adjust



图 3 调整后
Figure 3 After adjust



操作指引：

Operation guide:

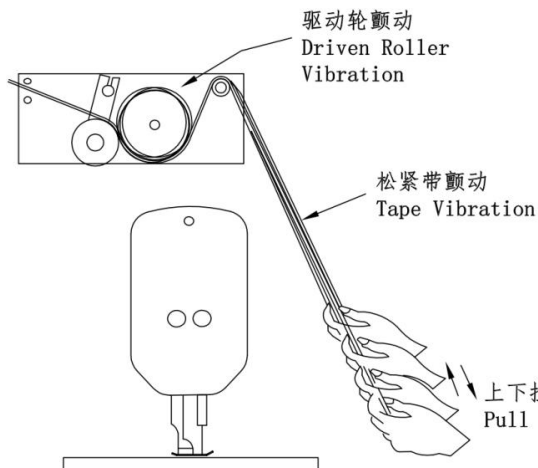
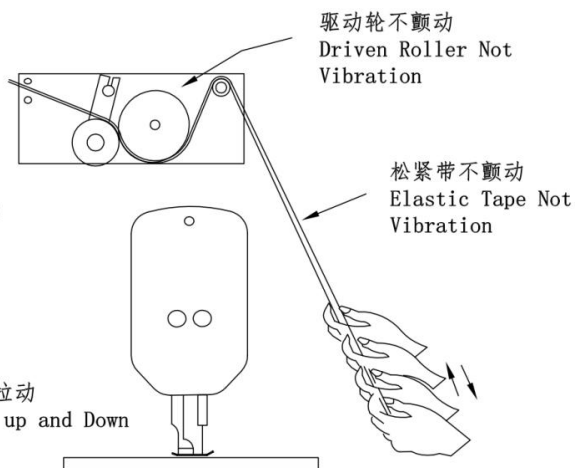
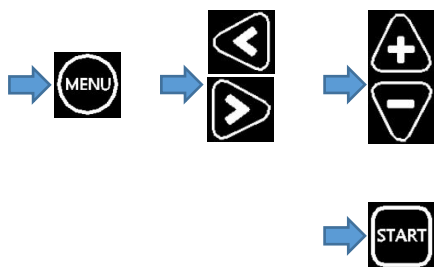

段值：8 (→1) 780
灵敏度：30
松带值：980
针数：000 工程：A

段值：Set-no
灵敏度：Sensitivity
松带值：Free tape
针数：Pin 工程：mode

段值：8 (→1) 780
灵敏度：90
松带值：980
针数：000 工程：A

零件图

PARTS LIST FOR MG3-8U SERIES

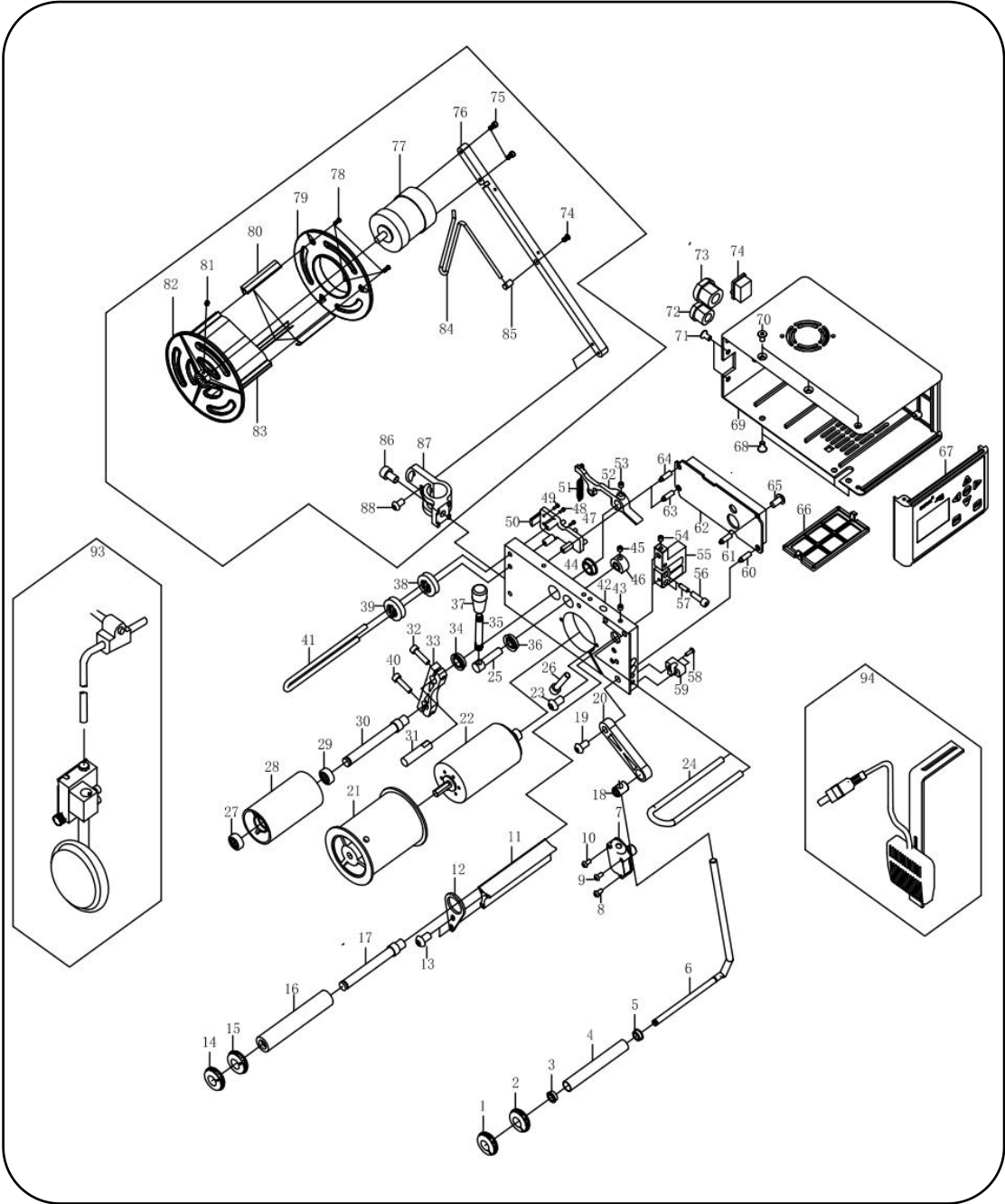

零件图

PARTS LIST FOR MG3-8U SERIES

95
安装支架 (标配)
Installation holder (standard)

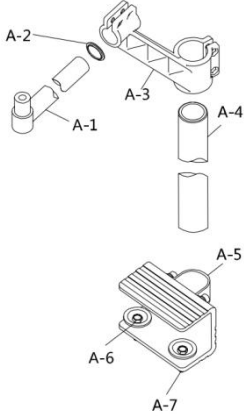

94
E8 膝部换段开关 (标配)
Knee switch (standard)

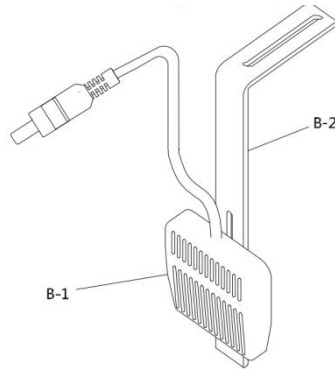

93
E9 无张力开关 (标配)
Zero-tension switch (standard)

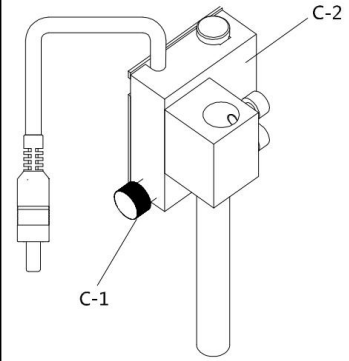

选配性配件

OPTIONAL PARTS

97
E6-1 悬吊
无张力开关 (选配)
Suspensory
zero-tension
switch(optional)

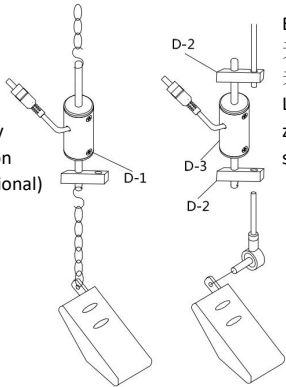

E6-2 连杆
无张力开关 (选配)
Linkage
zero-tension
switch(optional)

96
计数器 (选配)
SY Needle Counter (Optional)

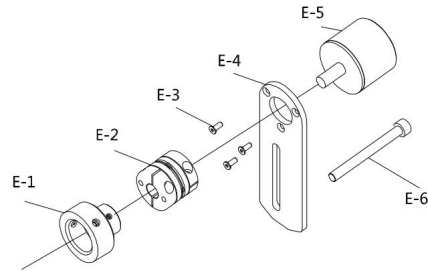

99
E10 缝纫机导带支架 (选配)
Zigzag machine tape
guiding holder(Optional)

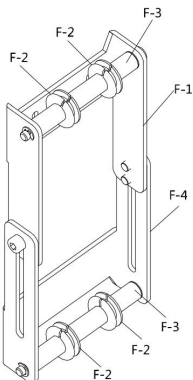

98
E11 缝纫机导带支架 (选配)
Interlock machine tape guiding holder(optional)

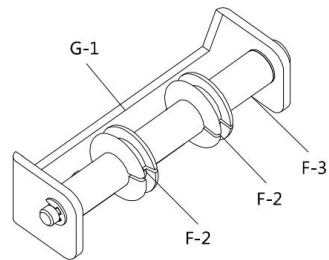

控制面板说明 CONTROL PANEL GUIDE



图 1
Figure 1

视窗及按键说明 (参照图 1):

Control panel instructions (refer to figure 1) :

- ①工程段数量: 指示当前工程组所包含的有效工程段数量
Total number of section: Indicate that how many section is available in a program
- ②当前工程段号: 指示当前正常使用的工程段号
Current section number: Indicate that which section is using
- ③松紧度设定: 显示当前工程段的松紧度设定值, 有效范围 1~999
Tension value: The current section tension value, it's free for set from 1 to 999
- ④灵敏度: 显示灵敏度设定值, 有效范围 1~99
Sensitivity value: Indicates the sensitivity which you have set from 1 to 99
- ⑤松带值: 显示松带设定值, 有效范围 1~980
Free tape: Indicates the free tape value from 1 ~ 980
- ⑥针数: 显示当前工程段的针数设定值, 用于自动换段, 最多针数 999 针
Pin / Stitch counting value: Show the stitch counting value of current section
- ⑦工程组: 显示当前工程组编号
Mode / Program number: Indicate that which program number is using
- ⑧启动键: 进入车缝模式用
Start key: Push start key to normal sewing operation
- ⑨模式键: 用于选择工程组, 共 12 组工程记忆可供用户选择
Mode key: Use this key to memorize up to 12 different program from A to Z
- ⑩菜单键: 用于进入工程参数设置或系统功能参数设置
Menu key: Used for enter project parameter setting or system parameter setting
- ⑪左移键: 用于选择参数
Left shift key: Used for parameter select
- ⑫右移键: 用于选择参数
Right shift key: Used for parameter select
- ⑬加键: 用于参数数值调节
Addition key: Used for parameter value modify
- ⑭减键: 用于参数数值调节
Subtract key: Used for parameter value modify

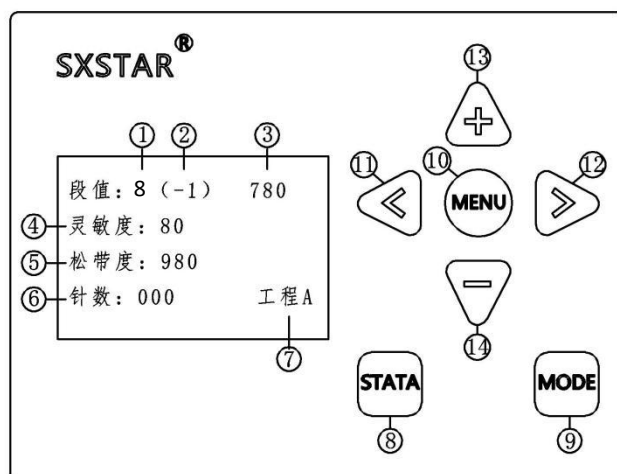
操控说明 OPERATION GUIDE

用户可按需求设置工程段数量

To set the total number of section according to actual usage

操作指引:

Operation guide:



段值: **Set-no**
灵敏度: **sensitivity**
松带值: **Free tape**
针数: **Pin** 工程: **mode**

段值: **8** (→1) 780
灵敏度: 80
松带值: 980
针数: 000 工程: A

段值: 7 (→1) 780
灵敏度: 80
松带值: 980
针数: 000 工程: A

针数设定说明:

STITCH SETTING GUIDE:

针数计数功能用于自动换段, 该功能需要搭配数针器使用, 如不需要自动换段功能, 在针数设定被选中时, 通过菜单键对针数功能进行开关操作(↓符号用于指示针数计数功能开关状态)

Stitch counting function is used for auto-section change(optional stitch counter required),it can be turn on or turn off by menu key when stitch counting value is selected.(↓ flag indicates the stitch counting function switch status)

操作指引:

Operation guide:

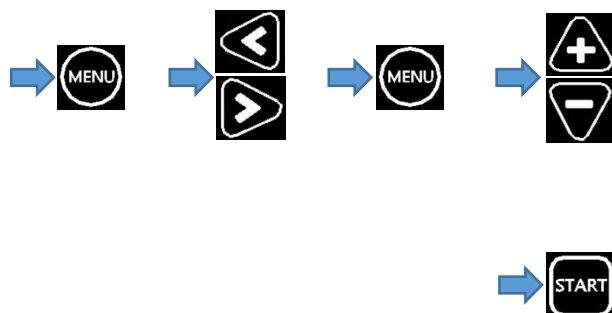

段值: **Set-no**
灵敏度: **sensitivity**
松带值: **Free tape**
针数: **Pin** 工程: **mode**

段值: **8** (→1) 780
灵敏度: 80
松带值: 980
针数: **000** 工程: A

段值: 8 (→1) 780
灵敏度: 80
松带值: 980
针数: 020 ↓ 工程: A

操控说明 OPERATION GUIDE

松带值操作说明

FREE TAPE OPERATION

松带值的设定：配合不同的松紧带，需要设定不同的值，否则值太多会造成松紧带太松而掉落，反之值太少使得松紧带太紧而移出布料（出厂设置：980）

Free tape operation guide : the different tape should use the different setting .otherwise,the free tape Function may cause too tight or too loose(the default is 980)

注意：此功能需要配合无张力开关操作使用

NOTICE:This function is used with Zero-tension switch

例 1：设定松带功能

Example 1: Setting free tape function

操作指引：

Operation guide:

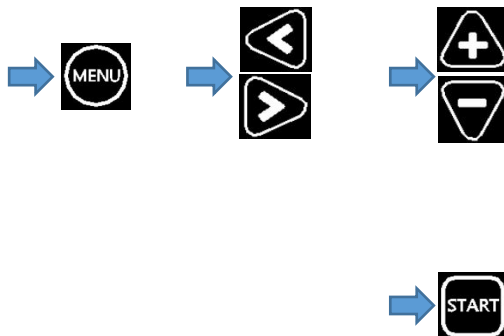

段值: **Set-no**

灵敏度: **sensitivity**

松带值: **Free tape**

针数: **Pin** 工程: **mode**

段值: 8 (→1) 780

灵敏度: 80

松带值: **980**

针数: 000 工程: A

段值: 8 (→1) 780

灵敏度: 80

松带值: 985

针数: 000 工程: A

操控说明 OPERATION GUIDE

工程记忆操作说明:

MODE OPERATION:

设备提供 12 组不同的工程组可选, 用户可快速选择事先存储的工程组, 无需重复设定

Provide 12 different program memory for select, user can rapidly switch the program which is already set, not necessary to re-set the program again.

例 2: 更换工程组, 由工程组 A 切换到工程组 B

Example 2: switch the program A to program B

模式 A
Program A

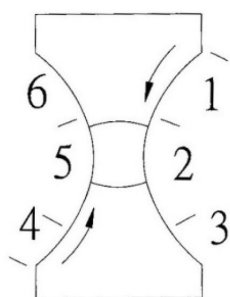

工程 Section	送料值 Feed	针数 stitch
1	750	105
2	680	122
3	735	
4	716	68
5	660	118
6	732	

模式 B
Program B

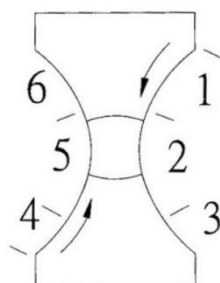

工程 Section	送料值 Feed	针数 stitch
1	750	100
2	680	120
3	735	
4	726	66
5	627	138
6	746	

操作指引:

Operation guide:

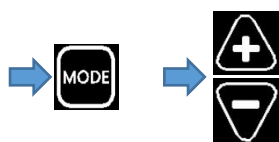

段值: 6 (→1) 780
灵敏度: 80
松带值: 980
针数: 000 工程: A

段值: Set-no
灵敏度: sensitivity
松带值: Free tape
针数: Pin 工程: mode



段值: 6 (→1) 800
灵敏度: 80
松带值: 980
针数: 000 工程: B

操控说明 OPERATION GUIDE

例 3: 单段工程
Example 3: Single section

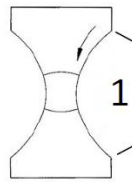

工程 Section	送料值 Feed	针数 stitch
1	750	

操作指引:
Operation guide:

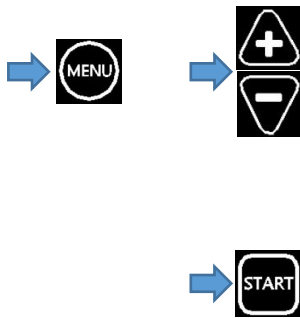



段值: 1 (→3) **780**
灵敏度: 80
松带值: 980
针数: 000 工程: A

段值: **Set-no**
灵敏度: **sensitivity**
松带值: **Free tape**
针数: **Pin** 工程: **mode**

段值: 1 (→3) 750
灵敏度: 80
松带值: 980
针数: 000 工程: A

料值送料值调整说明:
FEED VALUE ADJUSTMENT GUIDE:

 送料值小
Feed value lower

 送料值大
Feed value higher

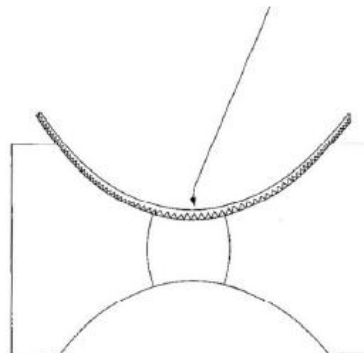
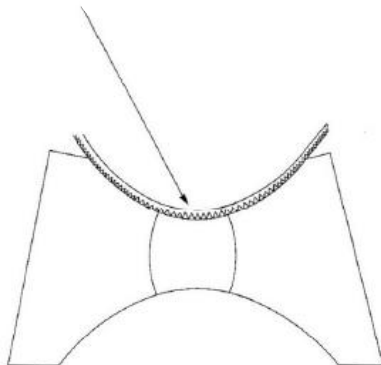

操控说明 OPERATION GUIDE

例 4: 6 段工程设定 (手动换段)

Example 4: six section setting
(section change by manual)

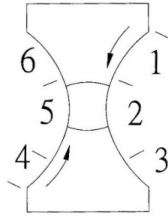

工程 Section	送料值 Feed	针数 stitch
1	750	
2	680	
3	735	
4	726	
5	672	
6	746	

操作指引:

Operation guide:

	<p>段值: Set-no 灵敏度: sensitivity 松带值: Free tape 针数: Pin 工程: mode</p>	<p>段值: 6 (→1) 750 灵敏度: 80 松带值: 980 针数: 000 工程: A</p>
	<p>段值: 6 (→2) 750 灵敏度: 80 松带值: 980 针数: 000 工程: A</p>	<p>段值: 6 (→2) 680 灵敏度: 80 松带值: 980 针数: 000 工程: A</p>
	<p>段值: 6 (→3) 750 灵敏度: 80 松带值: 980 针数: 000 工程: A</p>	<p>段值: 6 (→3) 735 灵敏度: 80 松带值: 980 针数: 000 工程: A</p>
	<p>段值: 6 (→4) 750 灵敏度: 80 松带值: 980 针数: 000 工程: A</p>	<p>段值: 6 (→4) 726 灵敏度: 80 松带值: 980 针数: 000 工程: A</p>
	<p>段值: 6 (→5) 750 灵敏度: 80 松带值: 980 针数: 000 工程: A</p>	<p>段值: 6 (→5) 672 灵敏度: 80 松带值: 980 针数: 000 工程: A</p>
	<p>段值: 6 (→6) 750 灵敏度: 80 松带值: 980 针数: 000 工程: A</p>	<p>段值: 6 (→6) 746 灵敏度: 80 松带值: 980 针数: 000 工程: A</p>

操控说明 OPERATION GUIDE

例 5: 1 段和 2 段为自动换段(需要搭配数针器)

Example 5: Section 1 and 2 are auto-section change (optional stitch counter required)

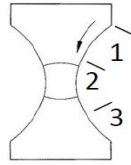

工程 Section	送料值 Feed	针数 stitch
1	750	100
2	680	120
3	735	

操作指引:

Operation guide:

	段值: Set-no 灵敏度: sensitivity 松带值: Free tape 针数: Pin 工程: mode	段值: 3 (→1) 750 灵敏度: 80 松带值: 980 针数: 000 工程: A
		段值: 3 (→1) 750 灵敏度: 80 松带值: 980 针数: 100 ↓ 工程: A
		段值: 3 (→ 2) 700 灵敏度: 80 松带值: 980 针数: 000 ↓ 工程: A
		段值: 3 (→2) 680 灵敏度: 80 松带值: 980 针数: 000 ↓ 工程: A
		段值: 3 (→2) 680 灵敏度: 80 松带值: 980 针数: 120 ↓ 工程: A
		段值: 3 (→ 3) 700 灵敏度: 80 松带值: 980 针数: 000 ↓ 工程: A
		段值: 3 (→3) 735 灵敏度: 80 松带值: 980 针数: 000 ↓ 工程: A

故障排除 TROUBLESHOOTING

问题现象 Symptom	原因 Cause	对策 Solution
送带机异常振动 Abnormal vibration	1. 支架各固定螺丝松动 2. 灵敏度值过高 1.Fixed screw loosen 2.The value of Sensitivity is too high	1. 上紧松池的螺丝 2. 降低灵敏度值 1.Check and Tighten the screws 2.Lower the value of sensitivity
送带数值 999 仍然过紧 999 still too tight	1. 感应杆有异物接触碰撞 2. 感应值不在正常范围	1. 请将异物移除 2. 参照归零校正, 如果不在 10-90 范围内, 通知维修人员进行维修
送带数值 001 仍然过松 001 still too loose	1. Something contact with the sensor bar 2.The sensor is not at the working range	1.Remove the irrelevant object 2.Redo the 0kg calibration.Call the technician to maintain if the value is not between 10-90
送带机无动作 No signal	1. 电源未接受 2. 线路系统断路 3. 控制系统故障 1.power is not connected properly 2.Connected line is break 3.Electronic control system error	1. 参考接线图接好电源 2. 检查各线路插座与插头接角是否松脱 3. 通知维修人员进行维修 1.Refer to wiring diagram connecting the power 2.Check the pin of connecting plug or socket are not close 3.Call the technician to maintain
荧幕不显示 Blank panel	面板故障 Panel out of order	通知维修人员进行维修 Call the technician to maintain
模式数值无法记忆 Cannot memorized the mode	记忆体故障 Memory out of order	通知维修人员进行维修 Call the technician to maintain
启动后, 松紧带无法回拉至所设计的松紧带 After turn on the power, The elastic tape can not Back to reach the setting tension	无张力开关动作不正常 Switcher of Free Tape is not working Properly Un-plug the Switches of Free Tape	请拆下无张力开关的电源插头后, 若可正常回拉则表示: 1. 无张力开关位置不良, 应调整 2. 无张力开关故障, 通知维修人员维修 If the elastic tape can pull back normally, it means: 1.The position of Switches if Free Tape is not in good position,Please re-adjust 2.The Switches of Free Tape is out of order, call the technician to maintain
车缝不准确 Unstable Elastic Size Control	1. 进带过程不流畅: 1-1. 限宽环太窄造成送带过程产生阻力 1-2. 车缝时松紧带与车头或其他物体接触产生摩擦 1.Un-smooth feeding path way for the Tape: 1-1.The width of Elastic Guide Rings for the Tape is too narrow to feed the tape 1-2.The Elastic Tape contacts to the Machine Head or other obstacle which causes friction	1-1 无压脚导引靠边器及压脚上之限位装置均需要调整略宽于松紧带 (注: 如因此造成车缝时松紧带左右移位时, 请调整限宽环的正确位置) 1-2 调整辅助杆, 将所有松紧带隔离所有接触的车头或物体 1-1.Adjust the proper width of All Guide include on the Pressure Foot(P.S. Pls.Re-location of Elastic Guide Rings,if the Tape is sliding to the right or left irregularly) 1-2.Use Auxiliary Roller to prevent the from contacting the machine or other obstacle
	2. 灵敏度调整不当 3. 缝制员手势熟练度及布料裁剪尺寸不均 2.Improper Sensitivity Setting 3.Unskilled operator and Irregularly cutting	2. 依松紧带材质的伸缩性调整灵敏度, 伸缩度越大灵敏度调整需越高, 但如果调太高灵敏度时会产生主机颤动不止, 而太多则会反应延缓产品尺寸的准确度 3. 缝制员在车缝过程中, 应保持手势给予布料一致的压力, 不可忽松忽紧, 且布料的裁剪尺寸要一致。 2.Pls.Re-setting the Sensitivity.More flexible tape is with higher value.It will cause vibration,if the value is too high.However,Lower value setting may cause slow reaction and causes incorrect tension 3.Operator must remain the same pressure to handle the sewing material and the cutting must be the same size
松紧带已经很松, 但车缝布料的效果仍然有褶皱无法平坦 Can not reach Flat sewing (Some situation need Flat sewing result)	因缝纫机的前差动齿, 差动太多, 送过多的布料 There is with too much differential Feed Ratio in order to feed too much material	调整缝纫机差动齿轮与主动齿的差动比为同步 (1: 1) Pls. Re-adjust the Differential Feed Ratio to 1: 1 range

